



BOARD OF TRUSTEES MEETING AGENDA

5:30 p.m., Monday, June 30, 2025
Hospital Meeting Rooms C-D
100 Medical Parkway, Denison, IA

- I. CALL TO ORDER**
- II. APPROVAL OF MINUTES**
 - A. Previous Month's Minutes
 - B. Previous Month's Minutes – Special Meeting
- III. QUALITY CARE AND SERVICES**
 - A. Quality Committee Report
 - B. Medical Staff Report
- IV. PATIENT EXPERIENCE**
 - A. 5 Star Journey Update
- V. PEOPLE**
 - A. Credentialing
 - i. Appointments & Reappointments – Discussion / Action
 - B. Mission Committee Report
- VI. GROWTH**
 - A. Department Reports
 - i. Education / Patient Experience
 - ii. Marketing
 - B. CEO Report
- VII. FINANCIAL STABILITY**
 - A. Finance Committee Report
 - i. Approval of Payroll & AP
 - B. Capital Purchase Ice Machine – Discussion / Action
 - C. Capital Purchase Office Furniture – Discussion / Action
 - D. FY26 Operating & Capital Budget – Discussion / Action
- VIII. COMMUNITY**
 - A. Board Chair Comments
- IX. ADJOURNMENT**

Our Mission

To provide convenient access to safe, high quality, patient centered healthcare by skilled and trusted professionals while exceeding customer expectations

Board of Trustees

May 19, 2025

A meeting of the Board of Trustees of Crawford County Memorial Hospital was held on Monday, May 19, 2025, in Hospital Board Room D at Crawford County Memorial Hospital, Denison, Iowa.

Present on site during the meeting were Jay Mendlik, David Reisz, Vernon Sid Leise, Jon Schuttinga, Amy Schultz, Theresa Sheer (CNO), Heather Rasmussen (Chief Quality Officer), Rachel Melby (CFO), Erin Muck (CEO), Dr. Michael Luft (Chief Medical Officer arrived at 5:32 and left at 6:09) and Heather Wight (Recorder). Also in attendance was Bob Fink (Director of Plant Operations left at 5:59). Not in attendance was Dr. David Wright (Chief of Staff).

CALL TO ORDER: The Board of Trustees meeting was called to order at 5:30 p.m. by Mendlik.

APPROVAL OF MINUTES

A motion was made by Reisz, second by Schuttinga, to approve the April 28, 2025, minutes as presented. Motion carried unanimously.

QUALITY CARE AND SERVICES

Quality Committee Report

- Rasmussen gave a brief update of the Quality Committee activities including sharing March HCHAPS scores and noted that the lab department's overall score rated in the 93%tile for the month.
- Recommend Board action regarding Medical Staff Accountable Care Committee recommendations for approval of Medical Staff privileges and appointment/re-appointment applications.

Medical Staff Report

Rasmussen shared that standards of care meetings were held. Theresa is actively working with Horn Memorial regarding Cerner workflow issues and will continue to meet as needed.

PATIENT EXPERIENCE

5-Star Journey Update

Muck shared the 5 Star calendar for June and July. It was decided at the SEC meeting that since we are no longer participating with CLS, that we would update the acronyms used to more plain language to help with confusion such as renaming the SEC (Service Excellence Council) to Patient Experience Committee and SEA (Service Excellence Advisor) to 5 Star Trainer.

PEOPLE

Credentialing

A motion was made by Schuttinga, second by Schultz, to approve Medical Staff new appointments of Carver, Eveloff, Kumari, Lewis and Walker and the reappointment of Carlson and Linde. Motion carried unanimously.

Mission Committee Report

The updated accountability dashboard was reviewed, highlighting key developments across several areas. In patient experience, the updated 5-Star Journey Plan calendar for summer activities, including SEA training and graduation, was shared. On the growth front, hospital procedures increased by 1.23% from

Board of Trustees

May 19, 2025

last April, with significant gains in ER, radiology, lab, pulmonary rehab, and cardiac rehab, though surgical procedures and clinic visits declined. Strategic planning session insights were also reviewed. Financially, the \$5.19 million redemption of the 2020C bonds, approved in January, will be completed on May 30th, reducing days cash by approximately 45 days. Finally, an update from the AHA Annual Meeting in Washington, D.C., provided important context on pending legislative impacts on healthcare and Medicaid.

GROWTH

Department Reports

Plant Operations: EVS & Maintenance

The Maintenance Department is actively engaged in spring lawn and landscaping work, supporting the construction project through coordination of shutdowns, HVAC tasks, and electrical layout planning, while also conducting pre-summer preventative maintenance on the cooling system. The EVS team is fully staffed and performing strongly, as reflected in high Press Ganey scores, bolstered by the addition of a second morning shift worker. Notably, EVS completed 188 (March) and 202 (April) Care Say rounding sessions, which have positively impacted survey results. Quality initiatives underway include quarterly Legionella testing, development of a Barrier Protection Plan to meet new fire safety requirements, and monthly ATP testing in selected hospital areas to monitor cleanliness. Additionally, biweekly ICRA (Infection Control Risk Assessment) inspections are being conducted in collaboration with Heather R. to mitigate infection risks from construction activities.

CEO Report

Muck shared that over the past year and a half, the BioVigil Hand Hygiene System has led to significant improvements in infection control and staff health, with plans to expand its use after Phase II. Patient experience initiatives include moving away from acronyms to enhance staff understanding and launching three Organizational Improvement projects aligned with quality goals. A new safety project is also underway to address workplace violence, based on employee feedback. June features several key events, including 5-Star Trainer graduation and employee forums to discuss upcoming building changes. Hospital Week and other appreciation events recognized staff contributions, and eight new interns will begin this summer. Growth efforts include finalizing a strategic plan and progressing with clinic construction, aiming for an August opening for the rehab services department. On the advocacy front, Muck attended the AHA Annual Meeting to address potential Medicaid cuts and their impact on Iowa hospitals, continuing to engage lawmakers for support.

FINANCIAL STABILITY

Finance Committee Report

1. Total Payroll & Accounts Payable of \$3,551,156.08 for payment.

A motion was made by Reisz, second by Schultz, to approve the financial report, total payroll, and accounts payables in the amount of \$3,551,156.08. Motion carried unanimously.

COMMUNITY

Board Chair Comments

Mendlik stated that there is nothing too out of the ordinary to report but we need to make sure we don't get too complacent with the Medicaid DPP funds as we don't know if they will be available next year.

Crawford County Memorial Hospital

Board of Trustees

May 19, 2025

We've been making good choices and improvements, and we are looking forward to seeing them come to fruition.

EXECUTIVE SESSION PURSUANT TO IOWA CODE

Section 21.5 (1)(I) To discuss marketing and pricing strategies and proprietary information where public disclosure of such information would harm the hospital's competitive position. Open Session – Possible Action

The Board went into Closed Session at 6:09 p.m. with a motion made by Schuttinga, second by Leise. Motion carried unanimously. Members present during the closed session were Jay Mendlik, David Reisz, Vernon Sid Leise, Jon Schuttinga, Amy Schultz, Theresa Sheer (CNO), Heather Rasmussen (Chief Quality Officer), Rachel Melby (CFO), Erin Muck (CEO), and Heather Wight (recorder).

A summary from strategic planning brainstorming session which included discussions of service lines, financials, reimbursement challenges, and physician/staff recruitment were discussed.

A motion was made at 6:55 p.m. by Leise, second by Schultz, to return the Board to Open Session. Motion carried unanimously.

No action was taken.

ADJOURNMENT

A motion was made by Leise, second by Reisz, that the meeting be adjourned at 6:56 p.m. Motion carried unanimously.

Crawford County Memorial Hospital

Board of Trustees

June 23, 2025

A meeting of the Board of Trustees of Crawford County Memorial Hospital was held on Monday, June 23, 2025, in Hospital Board Room D at Crawford County Memorial Hospital, Denison, Iowa.

Present on site during the meeting were Jay Mendlik, David Reisz, Vernon Sid Leise, Jon Schuttinga (arrived at 12:10), Amy Schultz, Erin Muck (CEO), and Heather Wight (Recorder). In addition, Macy Waldemar Webb (Director of Human Resources). Present via Webex was Lori Cole Magerko (MWH Law Group, LLP left at 12:48).

CALL TO ORDER: The Board of Trustees meeting was called to order at 12:07 p.m. by Mendlik.

EXECUTIVE SESSION PURSUANT TO IOWA CODE

Section 21.5 (1)(c) To discuss strategy with counsel in matters that are presently in litigation or where litigation is imminent where its disclosure would be likely to prejudice or disadvantage the position of the governmental body in that litigation.

The Board went into Closed Session at 12:08 p.m. with a motion made by Reisz, second by Leise. Motion carried unanimously. Members present during the closed session were Jay Mendlik, David Reisz, Vernon Sid Leise, Jon Schuttinga (arrived at 12:10), Amy Schultz, Erin Muck (CEO), Macy Waldemar Webb (Director of Human Resources), Lori Cole Magerko (MWH Law Group, LLP via Webex, left at 12:48), and Heather Wight (recorder).

A motion was made at 12:56 p.m. by Schultz, second by Schuttinga, to return the Board to Open Session. Motion carried unanimously.

No action was taken.

ADJOURNMENT

A motion was made by Schultz, second by Leise, that the meeting be adjourned at 12:56 p.m. Motion carried unanimously.

Crawford County Memorial Hospital
QUALITY COMMITTEE OF THE BOARD OF TRUSTEES
June 24, 2025 Meeting Minutes

A meeting of the Quality Committee of the Board of Trustees was held on Tuesday, June 24, 2025. Present: Jon Schuttinga, David Reisz, Michael Luft, DO (arrival 4:49pm), Erin Muck, CEO, Theresa Sheer, CNO, Heather Rasmussen, CQO, Dana Neemann, Director of Education and Patient Experience (exit 4:52pm), Brandi Ruskell, Marketing (exit 4:40pm).

Jon Schuttinga called the meeting to order at 4:31pm

Committee Recommendations/Actions: Recommend Board action regarding Medical Staff Executive Committee recommendations for approval of Medical Staff privileges and appointment/re-appointment applications.

I. Patient Experience

Neemann reviewed the updated April 2025 scorecard for HCAHPS. Inpatient has been scoring a lot of 4 out of 5 (good vs very good). The Medical Unit is working on moving the 4's to 5's (good to very good). The Emergency Department percentile rank for the month is 95%. A lot of work has been happening in the Emergency Department. Their Press Ganey scores are posted in the department. There continues to be a Cerner issue with Rehab Services. IT and Cerner continue to work on this.

II. Statistics

Muck reviewed May 2025 statistics with the Committee. Total patient days were down 5.58% for the month. Total hospital procedures were down 1.95% for the month, but inpatient procedures were up 22.59%, outpatient was down 2.88%. Skilled was up 166.67%. ER visits and ambulance trips were both down for the month. Increase in statistics were Lab 1.21%, and Radiology 7%, and Rehab 8.92%. Surgical procedures were down 13.59% for the month and are down 4.30% for the year. Muck reviewed detailed surgical statistics for FY2024-FY2025. Medical Clinic visits were down 14.52%.

III. Medical Staff Credentialing

The Committee members reviewed the recommendation from the Medical Staff Executive Committee for clinical privilege approval of the submitted applications for appointments/re-appointments. The Committee recommends approval action for the Board of Trustees.

IV. Committee Reports/Minutes

- i. **Medical Staff Meeting:** The Committee reviewed the minutes from the Medical Staff meeting held on June 10, 2025.
- ii. **PFAC:** Dana gave a brief update on the PFAC. The meetings will begin again on July 8th and will have seven (7) members.
- iii. **Accountability Scorecard:** The Committee reviewed an example of the Accountability Scorecard. The Accountability Scorecard will go live on July 1st.
- iv. **Departmental Reports:**
 - a. **Marketing:** Ruskell reviewed activities and initiatives, including social media & enhancements, digital signage, new advertising channels, website transition, team expansion, and community engagement and outreach. Ruskell and Muck discussed the Community Liaison position that has been posted.
 - b. **Patient Experience / Education:** Neemann gave an update on patient experience. There is now a Swing Bed Press Ganey survey for swing bed patients. The PFAC assisted in the creation of the Patient Resource Guide. Neemann reviewed education and professional development, including certifications, courses, continuing education, and training that the Education department has completed FY2025 YTD. Student engagement and tracking has been formalized.

- v. **Patient Experience Committee:** Sheer reviewed the minutes from the Patient Experience Committee on June 19th. She reviewed the June, July, and August calendars with the Committee. Employee Forums are underway.

V. Peer Review: Tabled

VI. Other Business/Updates

- i. **Recruitment:** Muck shared recruitment activities. Don Luensmann will be retiring in the near future. Muck received feedback from the Foundation on what they'd like to see in the Marketing and Foundation Director. His position has been posted and applications are being received. Senior Life Solutions are targeted to begin providing services in September or October this year. Muck shared that work has been ongoing for behavioral health via telemedicine in the RHC to possibly provide therapy and medication management twice a week. Dr. Rinek starts in the ER in August. PA and NP interviews continue. There are two upcoming NP interviews; one this week and one next week. Discussion has started on extending the RHC hours.
- ii. **Building Project:** Muck gave an update on Phase I and Phase II of the Building Project. Tours for the Board will be held on Monday, June 30th at 5:00pm.

VII. Adjournment Heather Rasmussen, Recorder. 5:34pm

Peer review records are privileged and confidential. Quality Improvement activities are protected from discovery under Iowa Code 147.135.

Crawford County Memorial Hospital

Medical Staff Meeting Minutes

June 10, 2025

A meeting of the Medical Staff of Crawford County Memorial Hospital was held on Tuesday, June 10, 2025 in the hospital's Meeting Room C & D.

Present were David Wright DO, Michael Luft DO, Patrick Luft MD, Julie Graeve ARNP, Benjamin Burkett MD, Richard Malyszczek MD, Laxmi Kumari MD, Erin Schechinger DNP, Cyilee Martin DNP, Jill Kierscht ARNP, Kylee LeFebvre ARNP, Angie Andersen, IT Director, Erin Muck CEO, Theresa Sheer CNO, Heather Rasmussen, Chief Quality Officer Recorder: Marcy Fink

Ad Hoc: Don Luensmann – Director of Marketing and Development, Brandi Ruskell – Marketing and Development Coordinator, Dana Neemann – Nurse Director of Education and Patient Experience

Absent: Elizabeth Ranniger MD, Sara Luft ARNP

The meeting was called to order by David Wright, DO at 8:02 a.m.

APPROVAL OF PREVIOUS MONTH'S MINUTES

The voting members of the Medical Staff approved the minutes of the May 13, 2025 meeting.

CNO UPDATE

Theresa Sheer

- Continuing to recruit for Medical Unit and EMS staff.
- EMS staff will no longer have 'call' shifts – they are all 'duty' shifts.

BUSINESS

A. Quality - Marketing

Don Luensmann & Brandi Ruskell

- a. Brandi gave an overview of what has been happening in the Marketing Department:
- Lilly Wyatt works on the social media and digital signage
 - The Foundation Golf Tournament will be held June 27th.
 - CCMH will have a booth at the Crawford County Fair. If any Providers would be interested in sitting at the booth, let someone in Marketing know.
 - Don Luensmann will be retiring in December.

B. Quality – Patient Experience and Education

Dana Neemann

- a. Dana gave a brief overview of Patient Experience and Education:
- The Fundamental Critical Care Support course will be held on Friday, June 13th, and Saturday, June 14th.
 - If any provider is interested in attending and speaking at one of the Care Support meetings, please let Dana know.

C. EKG Reads for Inpatient and ER

Erin Muck

- a. Discussion was held for Providers to read their own EKGs for Inpatient and ER. Erin will research the logistics of this.

D. IT Updates / Q&A

Angie Andersen

- a. The Stool Culture Synonym was unmapped. Providers may order:
- Culture, Stool (Salmonella, Shigella, Campy, Shiga Toxin) PLAB
 - Enteric Pathogen PLAB
- b. From here on out, wellness results will be routed to a generic "CCMH Provider" to not overwhelm Provider inboxes with results. They will still go into the patient's EMR. Lab will notify you of any critical labs.
- c. Working on immunization information going directly into IRIS.
- d. Starting July 1st, labs can be drawn in the clinic. You will order labs the same way.
- e. Matt from Cerner will be coming one last time. Will send update when a date has been decided.

ADJOURNMENT

The meeting was adjourned to the Executive Committee at 8:43 a.m.

David Wright, DO President, Medical Staff

JUNE 2025 CREDENTIALING

NEW APPOINTMENTS

Kolapo DaSilva, MD
Sarah Tweedy, CRNA

JUNE 2025 DISTANT SITE CREDENTIALING BY PROXY

NEW APPOINTMENTS

Crystal Lee Cook, PMHNP
Heidi Lane, PMHNP
Susan Selthofner, PMHNP
Tina Chavis, PMHNP
Shelby Sheehan, PMHNP
Nadia Luna, PMHNP
Sumeet Bahl, MD
Juan Lopez, MD
Michael Murphy Jr, MD

Crawford County Memorial Hospital
Mission Committee
June 19, 2025, 4:30 PM

A meeting of the Mission Committee of the Board of Trustees was held on Thursday, June 19, 2025. Present on site were Erin Muck (CEO), Vernon Sid Leise, Jay Mendlik, and Heather Wight (recorder). Not in attendance was Dr. Benjamin Burkett.

The meeting was called to order at 4:32 p.m.

QUALITY

Accountability Dashboard

- The updated accountability dashboard was reviewed.

PATIENT EXPERIENCE

5-Star Journey Plan Calendar

- Muck shared the updated 5 Star calendar for the summer including employee forums, 5 Star Workshop trainings and an outside speaker in August.

HCHAPS

- Muck shared the updated surveys have started and due to that there are some data lags. Departments that score under the 50% mark for their overall scores attend the Patient Experience Committee to share their progress and their improvement plans.

Patient Experience Committee Report – Organizational Improvement Projects Update

- Muck shared the 4 Organizational Improvement Projects (previously OASIS Teams) for this year which are Clinical Orientation/Staffing Fix, Huddle Boards, Department Accountability Scorecards and after staff input at employee forums, Workplace Safety was created.

PEOPLE

Recruitment Update

- Don Luensmann will be retiring at the end of the year so his position has been posted. The Community Liason position has been created and is being advertised. Family medicine screening calls continue and we recently had 3 Physician Assistant candidates onsite for interviews. There is an ER physician starting in August and another one in August of 2026.

FCCS

- The Fundamental Critical Care Course (FCCS) was held on Friday and Saturday last week. Ed Cutler, Drs. Wright and Malyszek and Patrick Stevens each gave demonstrations and did an amazing job. There was a total of 15 staff that attended. We are planning to host another course later in the year for the providers that were unable to attend this session.

GROWTH

Statistics

- Inpatient volumes were up 22% and while the total patient days were down, admissions were up, especially swing bed. Surgical procedures were up almost 14% and outpatient visits were up 63%.

Building Project Update – August Plans & Phase 2

- Muck shared updates for the opening of the new rehab services space along with tentative plans for Phase 2.

FINANCE

Medicaid Update

- The proposed Medicaid cuts from the Senate will likely have over a \$730 million-dollar negative impact to Iowa's Directed Payment Program. They have proposed decreasing the provider tax from 6% to 3.5% and decreasing Directed Payments from the average commercial rate to the Medicare rate. It is estimated that up to 10.3 million people will lose coverage. This will further exacerbate our significantly high uninsured rate.

FY26 Budget Update

- The summarized proposed FY26 operating and capital budgets were shared and discussed.

COMMUNITY

Community Health Needs Assessment

- The Community Health Needs Assessment has been completed and Don will have a summary for the September Board Meeting.

The meeting adjourned at 5:34 p.m. Heather Wight, Recorder



BOARD SUMMARY:

CEO Summary

By: Erin Muck, CEO

Date: June 26, 2025

SUMMARY:

Quality

The accountability scorecard that contains the restructure of the quality scorecard is almost finalized. This scorecard will be completed by each manager and will be reviewed monthly by medical staff, quality committee, and the Board Quality Committee. Any metric that requires enhancement will have an improvement project completed.

Patient Experience

Thank you to Dave for attending our 5-Star Trainer graduation. We have another outstanding group to lead our customer service training. Providers will also have the same training as frontline staff this year. The 5-Star Trainers will be meeting in a few weeks to set August's training dates and to start practicing.

Employee forums were this week. Topics included the opening of our new rehab services space late summer and walking through the multiple sub-phases of phase 2 of our project. Other topics included recruitment and behavioral health plans. We have also started to have one topic related to customer service. This month was about courteous communication.

People

Dr. Rinek will be starting in the ER in August, pending his Iowa license. We have another signed contract for an ER physician who will start August 2026. Interviews continue for family medicine physicians and advanced practice providers. We have had great PA and NP interviews and hope to have some offers out soon. The Director of Marketing and Foundation position has been posted to replace Don who retires by the end of this year.

CCMH hosted a Fundamental Critical Care Support (FCCS) course for our providers and staff. This very comprehensive class was attended by 15 providers and nurses. The course focuses on the necessary knowledge and skills needed to manage critically ill patients for the first 24 hours, or until critical care consultation can be arranged. We are working on arranging the course again to allow more staff to attend.

Growth

Behavioral health remains a significant need for our community. We are excited to begin implementing Senior Life Solutions (SLS) here in September or October. SLS is an outpatient program for older adults who have anxiety, depression, and other mental health conditions. We plan to utilize the outpatient space that Rehab Services is currently occupying.

Also in the next few months, we will be offering telemedicine behavioral health services for medication management and therapy. This will be staffed with a nurse practitioner two days a week and a therapist

two days a week. More details will be shared once a therapist and nurse practitioner has been credentialed.

Exploration of the expansion of clinic hours has started. To determine what the clinic hours should be, we are considering local needs as well as reviewing the hours of other clinics in rural Iowa. Once the hours are decided, decisions about staffing will begin. More to come.

There will be a tour of the building project progress at 5pm before the Board Meeting on Monday night. I am excited for you to see what all has occurred since your last tour.

Finance

As you consider the fiscal year 2026 budget and capital budget and beyond, it is important to take into consideration the proposed Medicaid cuts that were released by the U.S. Senate. These cuts are not finalized, but as of today it is estimated to have a \$730 million decrease in Iowa's Directed Payment Program starting in 2027. It is also estimated that up to 10.3 million people in the US will lose their Medicaid coverage. These cuts will likely increase our already high uninsured rate. I will continue to monitor this closely and will provide you with any updates as they become available.

Community

The Community Health Needs Assessment is being finalized and will be presented at September's board meeting.

The foundation is hosting their annual golf outing this Friday to raise money for new training manikins. CCMH provides many community opportunities to business and community members that need CPR certification, first aid, OSHA, and other trainings. These manikins will also support the multiple education opportunities that are provided internally to foster and grow the skills of our clinicians.

Respectfully,

Erin

**CRAWFORD COUNTY MEMORIAL HOSPITAL
FINANCE COMMITTEE MEETING
June 26, 2025, 12:00 P.M.**

A meeting of the Finance Committee of the Board of Trustees was held on June 26, 2025, in the Administrative Conference Room. Present on site were Rachel Melby (CFO), Erin Muck, (CEO), Jay Mendlik, Amy Schultz, and Heather Wight (recorder).

The meeting was called to order at 12:10 pm.

Committee Recommendations:

1. Total Payroll & Accounts Payable of \$3,551,156.08 for approval of payment.
2. Approve the Capital Purchase of an Ice Machine in the amount of \$5,259.56.
3. Approve the Capital Purchase of Office Furniture for Population Health in the amount of \$9,265.31.
4. Approve the FY2026 Operating and Capital Budgets.

Approval of Minutes

The May 2025 minutes were reviewed and approved.

CFO Report

The CFO Report was reviewed.

Financial Reports

Statistical, Income and Cash Flow Report

Overall, statistics were down approximately 2% compared to last May, with year-to-date volumes lagging by about 1% compared to the previous year. Departments with the greatest increases were Surgery up 14%, Outpatient Visits up 63%, Radiology up 7%, Physical Therapy up 9%, and Cardiac Rehab up 84%. Also included in this month's report is a detailed volume analysis for the month of May for both the Clinic and Surgery. With 1 month left in the fiscal year, we will have a full year-over-year statistical comparison at July's meeting.

Although volumes were down, the net profit for the month was \$1,485,891. As noted last month, we received our 4th quarter directed payment for FY2025 from Iowa Medicaid in May, which was a net distribution amount of \$1,718,527 and significantly decreased our deductions from revenue. Please note that without the Medicaid Directed Payments, which are currently in jeopardy with current legislation, our monthly net loss would have been \$232,636.

Due to the Medicaid directed payment, cash increased \$215,341 in May, bringing total cash with project funds to \$48,476,213 and days cash on hand to 417 days. Days cash on hand without project funds is 211 days. Also on a positive note, Days in A/R decreased from 63 days to 57 days and total accounts receivable decreased \$1.1 million.

Balance Sheet

The Balance Sheet as of 05/31/25 reflects Total Assets of \$88,299,132.

**CRAWFORD COUNTY MEMORIAL HOSPITAL
FINANCE COMMITTEE MEETING
June 26, 2025, 12:00 P.M.**

Payroll & Accounts Payable

The committee reviewed and recommends total Payroll & Accounts Payable of \$4,076,102.57 to the Board for approval. This amount includes \$2,587,761.66 in salaries.

Accounts Receivable

Patient Accounts Receivable as of 05/31/2025 totaled \$11,384,787 which is a decrease of \$1,148,952 from April.

Capital

Ice Machine

Repair costs to fix the ice machine in Same Day Services (currently Specialty Clinic) were quoted at \$3,000 for replacement parts. Under the CEO's signature authority, the decision was made to purchase a new ice machine for \$5,259.56. The machine has been ordered but needs final approval from the Board.

Office Furniture

The Population Health Manager was previously occupying an exam room in the Clinic. In order to move into an office in the hospital, new office furniture needed to be ordered which will allow the Manager to meet with patients and occupy an office in the same space. To get the order expedited and delivered timely, the CEO signed off on the purchase with her signature authority in the amount of \$9,265.31. The committee recommends the board sign off with final approval.

Other Business

FY2026 Operating Budget

The committee reviewed the FY2026 Operating Budget and recommends the Board approve the FY2026 Operating Budget. It was noted that there is still a lot of pending legislation that may significantly impact operations, but as always, we will adjust operations as needed.

FY2026 Capital Budget

The committee reviewed the FY2026 Capital Budget and recommends the Board approve the FY2026 Capital Budget. Capital requests totaled \$6,144,952 and the amount recommended for purchase is \$4,397,452. Within that total is the purchase of a new MRI, which is conservatively estimated at \$2,375,000. The committee will evaluate financing options prior to issuing a purchase order and will determine whether or not it makes fiscal sense to finance or pay cash at that time.

Adjourn - The meeting was adjourned at 1:06 p.m.

Crawford County Memorial Hospital

Comparative Statistical Report

May 2025

	Month to Date			Fiscal Year to Date		
	FY 2025	FY 2024	Variance	FY 2025	FY 2024	Variance
Total Admissions	30	29	3.45%	375	393	-4.58%
Acute/OB	21	22	-4.55%	308	299	3.01%
Skilled	8	3	166.67%	48	43	11.63%
ICF	1	2	-50.00%	14	5	180.00%
Respite	0	0	0.00%	1	0	100.00%
Newborns	0	2	-100.00%	4	46	-91.30%
Total Patient Days*	186	197	-5.58%	2,371	2,018	17.49%
Acute/OB	61	64	-4.69%	1,127	909	23.98%
Nursery	0	4	-100.00%	4	82	-95.12%
Skilled	53	26	103.85%	589	373	57.91%
ICF	1	3	-66.67%	37	9	311.11%
Respite	0	0	0.00%	3	0	100.00%
Observation	71	100	-29.00%	611	645	-5.27%
*Includes Observation						
Average LOS (Acute/OB)	3.04	3.34	-8.96%	3.46	3.10	11.82%
Hospital Procedures						
Inpatient	662	540	22.59%	9,969	7,607	31.05%
Outpatient	13,811	14,221	-2.88%	149,834	153,863	-2.62%
Total	14,473	14,761	-1.95%	159,803	161,470	-1.03%
Surgical Procedures	117	103	13.59%	1046	1093	-4.30%
Anesthesia Procedures	98	97	1.03%	826	900	-8.22%
ER Visits	409	468	-12.61%	5,004	4,716	6.11%
Admits from ER	19	28	-32.14%	302	284	6.34%
Scheduled Outpatient Visits	174	107	62.62%	1,208	1,127	7.19%
Ambulance Trips	107	149	-28.19%	1,210	1,296	-6.64%
Xray Procedures	671	602	11.46%	7,077	6,504	8.81%
Mammography Procedures	99	86	15.12%	1313	1329	-1.20%
Flouro Procedures	5	1	400.00%	35	16	118.75%
Ultrasound Dept Procedures	132	178	-25.84%	1718	1979	-13.19%
Echo Procedures	66	36	83.33%	454	446	1.79%
CT Dept Procedures	246	232	6.03%	2620	2285	14.66%
MRI Dept Procedures	88	85	3.53%	855	895	-4.47%
Nuc Med Procedures	7	8	-12.50%	49	71	-30.99%
Total Radiology Procedures	1,314	1,228	7.00%	14,121	13,525	4.41%
Respiratory Tx Procedures	74	189	-60.85%	838	1,464	-42.76%
EKG Procedures	117	196	-40.31%	1401	1828	-23.36%
Sleep Studies	30	14	114.29%	190	102	86.27%
Lab Procedures	6,953	6,870	1.21%	74,946	70,644	6.09%
Physical Tx Procedures	1,477	1,356	8.92%	17,459	19,307	-9.57%
Speech Procedures	34	20	70.00%	161	312	-48.40%
OT Procedures	166	173	-4.05%	1576	1758	-10.35%
Cardiac Rehab Procedures	169	92	83.70%	1442	1368	5.41%
Pulmonary Rehab Procedures	20	7	185.71%	149	100	49.00%
Specialty Clinic Visits	508	550	-7.64%	5,524	5,641	-2.07%
Total Medical Clinic Visits	2,813	3,291	-14.52%	33,912	37,585	-9.77%

**CRAWFORD COUNTY MEMORIAL HOSPITAL
OPERATING/INCOME STATEMENT
FOR THE MONTH ENDING MAY 31, 2025**

Gray lines are YTD. All %'s are based on net revenue except for the variance column and gross revenue.

	CURRENT MONTH ACTUAL		CURRENT MONTH BUDGET		CURRENT MONTH VARIANCE		PRIOR YEAR ACTUAL	
PATIENT SERVICE REVENUES								
INPATIENT SERVICES	713,352	10.9%	412,910	7.1%	300,442	72.8%	295,204	5.2%
	6,454,455	9.7%	4,438,907	7.1%	2,015,548	45.4%	4,304,397	7.3%
OUTPATIENT SERVICES	5,741,694	87.7%	5,363,460	91.9%	378,234	7.1%	5,299,175	93.9%
	59,141,669	88.5%	57,658,764	91.9%	1,482,904	2.6%	53,960,676	91.6%
SWING BED SERVICES	94,182	1.4%	61,089	1.0%	33,092	54.2%	49,719	0.9%
	1,215,928	1.8%	656,726	1.0%	559,203	85.2%	622,347	1.1%
TOTAL GROSS PATIENT REVENUE	6,549,228	100.0%	5,837,459	100.0%	711,768	12.2%	5,644,098	100.0%
	66,812,052	100.0%	62,754,396	100.0%	4,057,655	6.5%	58,887,420	100.0%
DEDUCTIONS FROM REVENUE								
MEDICARE ADJUSTMENTS	(1,723,035)	-26.3%	(1,313,077)	-22.5%	(409,958)	31.2%	(1,358,313)	-24.1%
	(14,791,960)	-22.1%	(14,115,960)	-22.5%	(676,000)	4.8%	(13,257,559)	-22.5%
TITLE XIX ADJUSTMENTS	1,739,913	26.6%	349,228	6.0%	1,390,685	398.2%	2,226,058	39.4%
	5,052,996	7.6%	3,754,307	6.0%	1,298,688	34.6%	1,876,382	3.2%
BLUE CROSS ADJUSTMENTS	(529,969)	-8.1%	(568,146)	-9.7%	38,177	-6.7%	(543,862)	-9.6%
	(6,772,576)	-10.1%	(6,107,740)	-9.7%	(664,836)	10.9%	(5,859,644)	-10.0%
OTHER ADJUSTMENTS	(502,231)	-7.7%	(292,940)	-5.0%	(209,292)	71.4%	(473,396)	-8.4%
	(4,025,355)	-6.0%	(3,149,188)	-5.0%	(876,168)	27.8%	(3,257,111)	-5.5%
PROVISION FOR UNCOLLECTIBLE	(230,119)	-3.5%	(155,930)	-2.7%	(74,189)	47.6%	(171,020)	-3.0%
	(1,800,285)	-2.7%	(1,676,298)	-2.7%	(123,987)	7.4%	(1,578,330)	-2.7%
CHARITY CARE	(17,778)	-0.3%	(23,775)	-0.4%	5,997	-25.2%	(2,689)	0.0%
	(163,667)	-0.2%	(255,590)	-0.4%	91,923	-36.0%	(224,194)	-0.4%
TOTAL DEDUCTIONS FROM REVENUE	(1,263,219)	-19.3%	(2,004,640)	-34.3%	741,421	-37.0%	(323,222)	-5.7%
	(22,500,848)	-33.7%	(21,550,468)	-34.3%	(950,380)	4.4%	(22,300,457)	-37.9%
NET PATIENT REVENUE	5,286,009	80.7%	3,832,819	65.7%	1,453,190	37.9%	5,320,877	94.3%
<i>(as % of Gross Patient Revenue)</i>	44,311,204	66.3%	41,203,929	65.7%	3,107,275	7.5%	36,586,963	62.1%
NET PATIENT REVENUE	5,286,009	97.6%	3,832,819	97.2%	1,453,190	37.9%	5,320,877	96.9%
<i>(as % of Total Operating Revenue)</i>	44,311,204	96.4%	41,203,929	97.1%	3,107,275	7.5%	36,586,963	95.9%
OTHER REVENUE								
DIETARY/MEALS INCOME	7,291	0.1%	6,308	0.2%	982	15.6%	5,356	0.1%
	74,244	0.2%	69,392	0.2%	4,852	7.0%	68,122	0.2%
OTHER INCOME	120,337	2.2%	105,875	2.7%	14,462	13.7%	164,661	3.0%
	1,591,736	3.5%	1,164,625	2.7%	427,111	36.7%	1,488,072	3.9%
TOTAL OTHER REVENUE	127,627	2.4%	112,183	2.8%	15,444	13.8%	170,016	3.1%
	1,665,979	3.6%	1,234,017	2.9%	431,963	35.0%	1,556,194	4.1%
TOTAL OPERATING REVENUE	5,413,636	100.0%	3,945,002	100.0%	1,468,634	37.2%	5,490,893	100.0%
	45,977,183	100.0%	42,437,945	100.0%	3,539,238	8.3%	38,143,157	100.0%
OPERATING EXPENSES								
SALARIES	1,677,049	31.0%	1,902,276	48.2%	(225,227)	-11.8%	1,545,323	28.1%
	18,560,976	40.4%	20,463,532	48.2%	(1,902,555)	-9.3%	18,209,508	47.7%
BENEFITS	510,743	9.4%	566,883	14.4%	(56,140)	-9.9%	506,875	9.2%
	6,060,552	13.2%	6,112,887	14.4%	(52,335)	-0.9%	5,489,522	14.4%
PROFESSIONAL FEES	449,602	8.3%	204,250	5.2%	245,352	120.1%	248,724	4.5%
	3,581,855	7.8%	2,197,200	5.2%	1,384,654	63.0%	3,001,376	7.9%
SUPPLIES & EXPENSES	1,200,528	22.2%	938,316	23.8%	262,211	27.9%	833,834	15.2%
	9,054,938	19.7%	10,608,581	25.0%	(1,553,643)	-14.6%	7,403,919	19.4%
OCCUPANCY	175,340	3.2%	136,415	3.5%	38,925	28.5%	129,576	2.4%
	1,679,040	3.7%	1,500,564	3.5%	178,476	11.9%	1,420,302	3.7%
DEPRECIATION	193,792	3.6%	186,375	4.7%	7,417	4.0%	183,150	3.3%
	2,131,708	4.6%	2,050,125	4.8%	81,583	4.0%	1,938,350	5.1%
TOTAL OPERATING EXPENSE	4,207,053	77.7%	3,934,516	99.7%	272,538	6.9%	3,447,482	62.8%
	41,069,069	89.3%	42,932,890	101.2%	(1,863,821)	-4.3%	37,462,977	98.2%
NET OPERATING INCOME (LOSS)	1,206,583	22.3%	10,487	0.3%	1,196,096	11406.0%	2,043,412	37.2%
	4,908,114	10.7%	(494,945)	-1.2%	5,403,059	-1091.6%	680,180	1.8%
NONOPERATING REV/EXP								
TAXES	181,742	3.4%	181,742	4.6%	-	0.0%	166,359	3.0%
	1,999,166	4.3%	1,999,166	4.7%	-	0.0%	1,829,944	4.8%
GENERAL CONTRIBUTIONS	-	0.0%	833	0.0%	(833)	0.0%	-	0.0%
	18,633	0.0%	9,167	0.0%	9,467	0.0%	17,990	0.0%
COVID/PRF/FEMA FUNDING	-	0.0%	-	0.0%	-	0.0%	-	0.0%
	-	0.0%	-	0.0%	-	0.0%	1,180,110	3.1%
INTEREST INCOME	142,799	2.6%	50,000	1.3%	92,799	185.6%	43,829	0.8%
	1,195,458	2.6%	550,000	1.3%	645,458	117.4%	549,651	1.4%
INTEREST EXPENSE	(45,233)	-0.8%	(162,119)	-45.2%	116,886	-72.1%	(47,313)	-0.9%
	(627,979)	-1.4%	(1,783,311)	-4.2%	1,155,332	-64.8%	(534,667)	-1.4%
WELLNESS CENTER CONTRIBUTIONS	-	0.0%	(41,667)	-5.3%	41,667	-100.0%	-	0.0%
	-	0.0%	(208,333)	-0.5%	208,333	-100.0%	-	0.0%
TOTAL NONOPERATING INCOME (LOSS)	279,308	5.2%	28,790	0.7%	250,519	870.2%	162,875	3.0%
	2,585,278	5.6%	566,688	1.3%	2,018,590	356.2%	3,043,027	8.0%
NET INCOME (LOSS)	1,485,891	27.4%	39,276	1.0%	1,446,615	3683.2%	2,206,286	40.2%
<i>Year to Date</i>	7,493,393	16.3%	71,743	0.2%	7,421,649	10344.7%	3,723,208	9.8%

**CRAWFORD COUNTY MEMORIAL HOSPITAL
STATEMENT OF CASH FLOWS
FOR THE MONTH ENDING MAY 31, 2025**

	<u>THIS MONTH</u>	<u>YTD</u>
CASH FLOWS FROM OPERATING ACTIVITIES		
CASH RECEIVED FROM PATIENTS AND THIRD-PARTY PAYORS	5,850,944	46,811,730
CASH PAID TO SUPPLIERS FOR GOODS AND SERVICES	(1,842,024)	(19,281,594)
CASH PAID TO EMPLOYEES FOR SERVICES	(2,497,705)	(21,000,191)
OTHER OPERATING REVENUE RECEIVED	127,627	1,936,489
NET CASH PROVIDED BY OPERATING ACTIVITIES	1,638,843	8,466,434
CASH FLOWS FROM NONCAPITAL FINANCING ACTIVITIES		
COUNTY TAXES	151,828	2,222,330
CASH FLOW FROM CAPITAL AND RELATED FINANCING ACTIVITIES		
PROCEEDS FROM ISSUANCE OF LONG-TERM DEBT	-	-
PRINCIPAL PAYMENTS ON LONG-TERM DEBT	(58,584)	(645,025)
INTEREST PAID ON LONG-TERM DEBT	(27,831)	(494,537)
ACQUISITION OF PROPERTY AND EQUIPMENT	(93,119)	(2,245,162)
CONSTRUCTION PROJECT FUNDS	(1,542,456)	16,250,805
NET CASH FROM (USED IN) CAPITAL AND RELATED FINANCING ACTIVITIES	(1,721,989)	12,866,081
CASH FLOW FROM INVESTING ACTIVITIES		
INTEREST RECEIVED	45,423	684,213
PROCEEDS FROM MATURITIES OF CERTIFICATES OF DEPOSIT	101,237	429,917
PURCHASE OF CERTIFICATE OF DEPOSIT	-	-
PROCEEDS OF MATURITIES OF U.S. GOVERNMENT AGENCY SECURITIES	-	77,058
PURCHASE OF GOVERNMENT AGENCY SECURITIES	-	-
NET CASH PROVIDED BY INVESTING ACTIVITIES	146,660	1,191,189
NET INCREASE (DECREASE) IN CASH	215,341	24,746,033
CASH		
BEGINNING	48,260,872	23,730,180
ENDING	48,476,213	48,476,213

<u>OPERATING INDICATORS:</u>	DEC	JAN	FEB	MAR	APR	MAY	Target	Desirable Trend
Total Margin:	-7.12%	12.58%	32.20%	3.88%	-3.97%	25.89%	2.00%	Increasing
Debt Service Coverage Ratio:	7.44	7.63	9.19	8.76	8.13	9.52	1.60	Increasing
Days Revenue in Patient A/R:	77	72	69	68	63	57	50	Increasing
Days Cash on Hand:	425	426	430	423	420	417	180	Increasing
(w/o Project funds)	(215)	(223)	(239)	(241)	(245)	(211)		

**CRAWFORD COUNTY MEMORIAL HOSPITAL
BALANCE SHEET
AS OF: 5/31/25**

<u>ASSETS</u>	Current Month		Prior Month		1-Month Net Change		1 Year Ago Month	
CURRENT ASSETS								
Total Cash	12,264,202	13.89%	15,512,438	17.72%	(3,248,235)	-20.94%	9,945,969	19.35%
Patient Receivables	11,384,787	12.89%	12,533,739	14.32%	(1,148,952)	-9.17%	9,746,249	18.97%
Allowance for Uncollectibles	(986,000)	-1.12%	(1,069,000)	-1.22%	83,000	-7.76%	(734,000)	-1.43%
Allowance for Contractuals	(3,730,000)	-4.22%	(4,150,000)	-4.74%	420,000	-10.12%	(3,070,000)	-5.97%
Net Accounts Receivable	6,668,787	7.55%	7,314,739	8.36%	(645,952)	-8.83%	5,942,249	11.56%
Other Receivables								
Est. Third Party Settlement	-	0.00%	-	0.00%	-	0.00%	-	0.00%
Taxes Receivable	(24,837)	-0.03%	126,991	0.15%	(151,828)	-119.6%	(54,789)	-0.11%
Other	236,821	0.27%	214,684	0.25%	22,137	10.31%	655,261	1.28%
Inventory	1,494,893	1.69%	1,474,752	1.68%	20,141	1.37%	1,435,573	2.79%
Prepaid Expenses & Other	549,777	0.62%	710,980	0.81%	(161,202)	-22.67%	1,302,965	2.54%
TOTAL CURRENT ASSETS	21,189,644	24.00%	25,354,583	28.96%	(4,164,939)	-16.43%	19,227,228	37.42%
ASSETS LIMITED AS TO USE								
Investments								
Cash & CD's	12,210,480	13.83%	12,655,900	14.46%	(445,420)	-3.52%	13,152,327	25.59%
Bond/Project Funds	24,001,531	27.18%	20,092,534	22.95%	3,908,996	19.45%	605,630	1.18%
Interest Receivable	85,732	0.10%	89,613	0.10%	(3,881)	-4.33%	103,080	0.20%
TOTAL ASSETS LIMITED AS TO USE	36,297,743	41.11%	32,838,047	37.51%	3,459,696	10.54%	13,861,037	26.97%
OTHER ASSETS								
Physician Practice Intangibles	815,000	0.92%	815,000	0.93%	-	100.00%	815,000	1.59%
TOTAL OTHER ASSETS	815,000	0.92%	815,000	0.93%	-	0.00%	815,000	1.59%
PROPERTY & EQUIPMENT, NET								
Land	314,500	0.36%	314,500	0.36%	-	0.00%	314,500	0.61%
Land held for Future Dev	120,400	0.14%	120,400	0.14%	-	0.00%	120,400	0.23%
Land Improvements	2,623,208	2.97%	2,623,208	3.00%	-	0.00%	2,511,827	4.89%
Building	8,675,741	9.83%	8,675,741	9.91%	-	0.00%	8,670,091	16.87%
Fixed Equipment	18,250,614	20.67%	18,242,924	20.84%	7,690	0.04%	18,070,916	35.16%
Major Moveable Equipment	22,508,773	25.49%	22,425,660	25.62%	83,113	0.37%	19,147,847	37.26%
Leased Equipment	1,439,076	1.63%	1,439,076	1.64%	-	0.00%	1,439,076	2.80%
Deferred Costs	11,247,767	12.74%	9,682,485	11.06%	1,565,282	16.17%	1,608,733	3.13%
Right of Use Subscriptions	201,265	0.23%	201,265	0.23%	-	0.00%	-	0.00%
Allowance for Depreciation	(40,280,645)	-45.62%	(40,086,854)	-45.79%	(193,792)	0.48%	(37,995,704)	-73.94%
TOTAL PROPERTY & EQUIP, NET	25,100,698	28.43%	23,638,405	27.00%	1,462,293	6.19%	13,887,686	27.02%
DEFERRED OUTFLOWS OF RESOURCES								
Pension Related Deferred Outflows	4,134,804	4.68%	4,134,804	4.72%	-	0.00%	2,767,672	5.39%
Deferred Loss on Refunding	761,243	0.86%	761,243	0.87%	-	0.00%	830,448	1.62%
TOTAL DEFERRED OUTFLOWS	4,896,047	5.54%	4,896,047	5.59%	-	0.00%	3,598,120	7.00%
TOTAL ASSETS	88,299,132	100.00%	87,542,083	100.00%	757,050	0.86%	51,389,069	100.00%
LIABILITIES & NET ASSETS								
CURRENT LIABILITIES								
Accounts Payable	400,718	0.45%	207,132	0.24%	193,586	93.46%	253,877	0.49%
Accrued Payroll & Payroll Taxes	1,510,217	1.71%	2,175,498	2.49%	(665,281)	-30.58%	1,779,572	3.46%
Accrued Health Insurance	2,100,992	2.38%	2,153,902	2.46%	(52,910)	-2.46%	1,851,321	3.60%
Deferred Pro Tax Receivable	181,742	0.21%	363,485	0.42%	(181,742)	-50.00%	166,359	0.32%
Due to Third Parties - Other	20,810	0.02%	2,102	0.00%	18,707	889.87%	14,862	0.03%
Lease Payable - Short Term	61,722	0.07%	61,722	0.07%	-	0.00%	-	0.00%
Est. Third Party Settlements	1,737,575	1.97%	1,737,575	1.98%	-	0.00%	1,797,452	3.50%
TOTAL CURRENT LIABILITIES	6,013,776	6.81%	6,701,416	7.66%	(687,640)	-10.26%	5,863,443	11.41%
OTHER LIABILITIES								
Lease Payable - Long Term	68,886	0.08%	72,302	0.08%	(3,416)	-4.72%	59,880	0.12%
Bonds Payable - Long Term	43,237,986	48.97%	43,293,154	49.45%	(55,168)	-0.13%	18,714,858	36.41%
Interest Payable	179,761	0.20%	162,378	0.19%	17,382	10.70%	135,252	0.26%
Net Pension Liability	9,673,976	10.96%	9,673,976	11.05%	-	0.00%	7,660,095	14.90%
TOTAL LONG-TERM LIABILITIES	53,160,608	60.21%	53,201,809	60.77%	(41,201)	-0.08%	26,570,084	51.69%
TOTAL LIABILITIES	59,174,384	67.02%	59,903,225	68.43%	(728,841)	-1.22%	32,433,527	63.10%
DEFERRED INFLOWS OF RESOURCES								
Pension Related Deferred Inflows	774,116	0.88%	774,116	0.88%	-	0.00%	2,013,105	3.92%
OPEB Related Deferred Inflows	300,736	0.34%	300,736	0.34%	-	0.00%	175,696	0.34%
TOTAL DEFERRED INFLOWS	1,074,852	1.22%	1,074,852	1.23%	-	0.00%	2,188,801	4.26%
NET ASSETS								
General Fund	20,556,504	23.28%	20,556,504	23.48%	-	0.00%	13,053,534	25.40%
Net Revenue (Loss)	7,493,393	8.49%	6,007,502	6.86%	1,485,891	24.73%	3,723,208	7.24%
TOTAL NET ASSETS	28,049,897	31.77%	26,564,006	30.34%	1,485,891	5.59%	16,776,742	32.64%
TOTAL LIABILITIES & NET ASSETS	88,299,132	100.00%	87,542,083	100.00%	757,050	0.86%	51,399,069	100.00%

TO BE PAID THIS MONTH -MAY 2025

AbbVie US, LLC - Supplies	\$1,968.00	Jenny Frank - Expenses	\$54.15
Access Technologies - Fees	\$181.00	Frontier Telephone Co. - Telephone	\$252.38
Advanced Sterilization Products - Supplies	\$10,535.99	GE Medical Systems Information Tech - Fees	\$607.26
Agiliti Surgical Equipment Repair, Inc. - Supplies	\$854.40	Genzyme Corporation - Supplies	\$2,210.00
Airgas USA - Supplies	\$5,180.25	GQR Recruiting Resources LLC - Fees	\$42,598.35
Alcon Vision, LLC - Supplies	\$6,271.86	Grainger - Supplies	\$1,005.97
Alcor Scientific - Supplies	\$3,153.82	Jamie Gross - Expenses	\$34.86
American Surgical Specialties Co. - Supplies	\$630.66	GRP & Associates Inc. - Fees	\$524.42
Ameritex Services - Fees	\$6,170.65	Brooke Guajardo - Expenses	\$224.70
Ampride Tire & Auto Center - Fees	\$156.09	H&R Accounts, Inc. - Fees	\$9,833.06
Anderson Erickson - Supplies	\$338.17	Jesyca Haines - Fees	\$11,232.60
Applied Medical - Supplies	\$391.00	Health Care Logistics, Inc. - Fees	\$115.18
Amber Baak - Expenses	\$39.59	Health Partners of Southwest Iowa - Fees	\$3,713.00
Bayer Healthcare - Supplies	\$1,793.22	Healthcare Compliance Testing, Inc. - Fees	\$450.00
Beckman Coulter, Inc. - Supplies	\$8,298.22	Healthmark Industries Co, Inc. - Supplies	\$81.29
Tracie Bergman - Expenses	\$111.08	Heartland Business Systems, LLC - Fees	\$9,178.54
Biocomposites, Inc. - Supplies	\$1,550.00	Highland Medical Staffing - Fees	\$1,309.80
Biovigil Technologies, LLC - Fees	\$2,198.49	HMH Foundation - Sponsorship	\$400.00
Bluespace Creative - Fees	\$770.00	Home Depot Pro - Supplies	\$247.67
Bomgaars - Supplies	\$432.85	HyVee, Inc. - Supplies	\$1,008.00
Boss Instruments, LTD - Supplies	\$55.50	ICAN, Inc. - Advertising	\$255.00
Boston Scientific Corporation - Supplies	\$1,408.35	ICP Medical, LLC - Supplies	\$640.00
Bound Tree Medical - Supplies	\$325.80	ICU Medical, Inc. - Supplies	\$3,607.62
Bracco Diagnostics, Inc. - Supplies	\$1,220.40	Iowa Association of Rural Health Clinics - Fees	\$275.00
Debra Brock - Expenses	\$179.76	J&J Health Care Systems, Inc. - Supplies	\$84,972.50
Bulletin- Review - Fees	\$74.99	Jackson Physician Search, LLC - Fees	\$26,288.38
Butterfly Network, Inc. - Supplies	\$1,200.00	Jaeger Medical America, Inc. - Supplies	\$587.92
C R Bard, Inc. - Supplies	\$383.75	John Deere Financial - Supplies	\$55.95
Cardinal Health - Supplies	\$58,185.37	JP Gasway Co. - Supplies	\$1,580.00
Cardinal Supplies and Fresheners - Supplies	\$52.80	JP Turf and Pest, LLC - Fees	\$66.00
Scott Carver - Fees	\$10,700.00	Barb Kacmarynski - Fees	\$428.00
CDW Government, Inc. - Supplies	\$3,027.94	KCI USA, INC. - Supplied	\$3,202.67
Central Iowa Detention - Fees	\$1,021.45	KDSN FM - Advertising	\$3,461.68
CenturyLink - Telephone	\$512.87	Kicktech, LLC - Fees	\$6,900.50
Cepheid - Supplies	\$4,861.86	Makayla Kintner - Expenses	\$65.80
Cerner Corporation - Fees	\$35,884.00	Kiron Fire Department - Sponsorship	\$500.00
Change Healthcare - Fees	\$5,648.52	Knowles Publishing Corp. - Advertising	\$2,455.50
CHI Health - Fees	\$3,702.47	La Prensa - Advertising	\$1,800.00
Cobblestone Inn & Suites - Fees	\$3,510.00	Landauer, Inc. - Supplies	\$425.17
Colonial Life - Premiums	\$587.54	Language Lines Services - Fees	\$213.73
CompHealth - Fees	\$41,235.15	Skye Lapel - Expenses	\$308.80
Constellation Newenergy - Utilities	\$15,190.82	Life Instrument Corporation - Supplies	\$3,500.00
Consulting Remedy, LLC - Fees	\$3,080.00	Lifeserve Blood Center - Fees	\$5,373.69
Controlled Comfort - Fees	\$21,981.81	Little Ponies, LLC - Sponsorship	\$250.00
Convergeone, Inc. - Supplies	\$288.00	Marco Helix LLC - Fees	\$13,693.76
Crawford County EMS Assoc. - Sponsorship	\$300.00	Craig Malone - Rent	\$650.00
Crawford County Home Health - Fees	\$47.80	Manilla Times - Advertising	\$625.96
Cutler Anesthesia Services - Fees	\$56,080.00	Mapleton Press - Advertising	\$243.00
Dearborn - Premiums	\$21,420.99	Marco Technologies, LLC - Fees	\$18,433.95
Dell Marketing LP - Supplies	\$1,646.49	Martin Bros Dist. Co., Inc - Supplies	\$4,038.63
Denison Bulletin & Review -Advertising	\$609.20	Cyilee Martin - Expenses	\$990.00
Denison Free Press - Advertising	\$700.00	McGowan Industries, Inc. - Supplies	\$40.00
Denison Municipal Utilities - Utilities	\$15,013.29	McKesson Medical Surgical - Supplies	\$5,123.54
Denman CPA, LLP - Fees	\$4,600.00	Medbridge, Inc. - Supplies	\$120.76
DirectTV - Fees	\$798.25	Medibadge, Inc. - Supplies	\$34.00
Do It Best Hardware - Supplies	\$20.97	Medical Solutions - Fees	\$122,358.41
Dorsey & Whitney, LLP - Fees	\$2,789.50	Medimizer Software - Fees	\$1,430.57
Dutch Ophthalmic, USA - Supplies	\$836.50	Medline Industries LP - Supplies	\$4,107.54
Echo Group, Inc. - Supplies	\$477.95	Mid-American Publishing Corp. - Advertising	\$30.00
Egold Fax - Fees	\$1,223.10	MidAmerican Energy - Utilities	\$76.09
El Mexicano - Fees	\$0.00	Mindray DS USA, Inc. - Supplies	\$1,267.52
Encision, Inc. - Supplies	\$1,111.43	Dr. Stephen Morse - Fees	\$65,125.70
Amanda Eneboe - Expenses	\$217.82	Motorola Solutions, Inc. - Supplies	\$2,316.00
Ace Etleman - Rent	\$550.00	Erin Muck - Expenses	\$829.38
Dr. Scott Eugene Eveloff - Fees	\$2,050.00	MWH Law Group, LLP - Fees	\$6,956.00
Eventide Lutheran Home - Fees	\$1,102.50	NASCO Healthcare, Inc. - Supplies	\$2,415.27
Fareway Stores - Supplies	\$617.10	Nebraska Medicine - Fees	\$1,250.00
Farmer Bros. Co. - Supplies	\$740.94	Neighbors Business Review - Advertising	\$139.50
Federal Express Corp. - Fees	\$38.83	Network Services Company - Supplies	\$2,126.33
Feld Fire - Fees	\$105.00	Netwrix Corporation - Fees	\$4,929.70
FFF Enterprises, Inc. - Supplies	\$3,823.35	New Century FS - Fuel	\$1,882.86
Robert Fink - Expenses	\$1,071.70	New York Life - Premiums	\$2,820.52
First National Bank Omaha - Expenses	\$12,162.16	Nuance Communications, Inc. - Supplies	\$1,476.66
First Wireless - Supplies	\$19,464.00	NW Iowa Yes Center - Fees	\$1,038.90

Observer - Advertising	\$678.22	Steris Corporation - Supplies	\$3,015.80
Omniceil, Inc. - Fees	\$80.00	Stryker Orthopedics - Supplies	\$37,436.00
Onmedia - Advertising	\$416.00	Stryker Sales LLC - Supplies	\$4,905.35
O'Reilly Auto Parts - Supplies	\$24.77	Sweet Treats & More - Fees	\$218.00
Orthalign, Inc. - Supplies	\$1,995.00	Team Ford Lincoln - Fees	\$64.24
Owens & Minor - Supplies	\$24,488.19	Teleflex LLC - Fees	\$307.00
Oxen Technology - Fees	\$11.00	Tennant Sales and Service Co. - Fees	\$4,886.54
Parks Medical Electronics, Inc. - Supplies	\$5,685.00	The Cottage - Fees	\$1,990.00
Partssource, Inc. - Supplies	\$134.05	The Old Fashioned - Fees	\$348.40
Performance Health Supply LLC - Supplies	\$153.46	Thrifty White - Fees	\$17.54
Kim Petersen - Expenses	\$471.64	Tri-Anim Health Services - Supplies	\$1,656.88
Lana Peterson - Expenses	\$129.78	TruBridge - Fees	\$2,609.00
Pharmacy OneSource - Supplies	\$560.16	Tusk Enterprises, LLC - Supplies	\$12,462.40
Phoenix Textile Corp - Supplies	\$166.56	UKG, Inc. - Fees	\$1,794.31
Physician Lab Services - Fees	\$56,197.00	Uniguest - fees	\$3,451.68
Samantha Pick - Expenses	\$273.32	UnityPoint Health - Fees	\$378.00
Pipeline Health Holdings, LLC - Fees	\$5,427.43	US Foods - Supplies	\$7,944.59
Positive Promotions - Supplies	\$2,269.56	V&H Tire Co., Inc. - Fees	\$26.75
PPP Web Design - Fees	\$190.00	Van Houten Acres - Sponsorship	\$300.00
Practical Sleep Services, LLC - Fees	\$8,220.00	Vanessa McNeal, LLC - Fees	\$5,000.00
Professional Computer Solutions - Fees	\$293.00	VelocityEHS, Inc. - Supplies	\$4,041.67
Professional Medical Management - Supplies	\$7,287.50	Verizon Wireless - Telephone	\$588.08
Propio Language Service - Fees	\$1,057.35	Trama Vetter - Expenses	\$351.50
Qgenda, LLC - Fees	\$465.45	Vision Service Plan - Premiums	\$3,744.05
QuVa Pharma, Inc. - Supplies	\$394.85	Visual Edge IT, Inc. - Fees	\$1,514.81
R&S Waste Disposal - Fees	\$1,193.02	VVC Holding LLC - Supplies	\$5,036.13
Rasmussen Mechanical Services - Fees	\$1,912.48	Macy Waldemar Webb - Expenses	\$333.89
Redsail Technologies - Fees	\$1.57	Walmart / Capital One - Supplies	\$563.97
REK Anesthesia - Fees	\$6,925.00	Wells Fargo Financial Lease - Fees	\$935.18
Rolling Hills Community Service - Fees	\$4,785.00	Western Iowa Networks - Fees	\$1,663.63
Scribe EMR - Fees	\$13,111.90	Westside sonography, Inc. - Fees	\$720.00
Secure Shred Solutions - Fees	\$232.00	Kelly Wieman - Expenses	\$320.99
Shared Medical Services, Inc. - Supplies	\$2,257.50	WIN - Fees	\$1,500.00
Shared Medical Technology - Fees	\$5,147.00	Tracie Winans - Expenses	\$227.92
Theresa Sheer - Expenses	\$151.77	WIPFLI - Fees	\$17,405.60
Siemens Healthcare Diagnostics - Supplies	\$2,156.51	Jessica Wood - Expenses	\$453.96
Society of Critical Care Medicine - Fees	\$1,800.00	Wynden Stark, LLC - Fees	\$24,440.30
SpendMend, LLC - Supplies	\$3,305.05	Zimmer US, Inc. - Supplies	\$125.26
St. Anthony Regional Hospital - Fees	\$2,695.00	Patient Account Refunds	\$18,039.29
Staples Advantage - Supplies	\$696.74		

May Check Run **\$1,248,087.59**

DEPRECIATION FUND:

ACME Dock Specialists, Inc. - Loading Dock	\$7,690.00
Carroll Control Systems, Inc. - Facility Project	\$91,524.00
Certified Testing Services, Inc. - Facility Project	\$7,135.20
Cornerstone Commissioning - Facility Project	\$6,422.00
Invision Architecture - Facility Project	\$36,206.09
Lint Van Lines - Facility Project	\$1,472.00
Motorola Solutions, Inc. - Radios	\$40,297.98
Parks Medical Electronics, Inc. - U/S Flow Lab	\$42,815.00
VOC Associates, LLC - Facility Project	\$6,691.05

Depreciation Total **\$240,253.32**

Salaries **\$2,587,761.66**

GRAND TOTAL **\$4,076,102.57**

**Crawford County Memorial Hospital
PURCHASING DEPARTMENT REQUEST
Capital & Minor Equipment**

Date: 5/21/25

Department: SAME DAY/SPEC CLINIC ^{FC}

Capital Equipment Item (>\$5,000): Yes Minor Equipment (\$1,000-\$5,000): Yes

In Current Fiscal Year Budget: Yes No

Is this a trial? Yes No If Yes, length of trial _____

If replacement, what item does it replace? _____

Item Requested: FOLLETT ICE MACHINE

Quantity: 1

Description: _____

Justification of purchase: OLD MACHINE DIED, WOULD COST 3000.00 FOR PARTS

Pricing reviewed by MM: CT ASCEND contract _____ MD Buyline checked _____

Reviewed by IT: _____ Reviewed by Plant Operations: BF

Reviewed by Bio-Med: _____ Service Manual Ordered: _____

Company #1: FOLLETT # 5259 56 In Buying Group? Yes No

Company #2: _____ Yes No

Company #3: _____ Yes No

Recommendation: _____

Approved for purchase from _____ (Company)

Purchase Order #: _____ Date: _____

Signature: 
Department Manager

Signature: 
CEO/CFO

CRAWFORD COUNTY MEMORIAL HOSPITAL
100 MEDICAL PARKWAY
DENISON, IA 51442

Phone: 712-265-2500

PURCHASE ORDER

Purchase Order No.:	44045
Company No.:	CCMH
Vendor No.:	104386
Page No.:	1 of 1

Purchase Order Number above must appear on all correspondence.

VENDOR
FOLLETT PRODUCTS, LLC P.O. BOX 782806 PHILADELPHIA, PA 19178-2806 PHONE: 800-523-9361 FAX: ACCT: 012068

INSTRUCTIONS
ADD ON CAPITAL FOR SAMEDAY SERVICES. OLD MACHINE WENT DOWN. QUOTE#61712

SHIP TO
CRAWFORD COUNTY MEMORIAL HOSPITAL 100 MEDICAL PARKWAY DENISON, IA 51442

PAYMENT TERMS	FREIGHT TERMS	ORDER DATE
Due 30 Days		May 22, 2025

LINE	CATALOG	ITEM #	DESCRIPTION	QTY	UOM	PRICE	AMOUNT
1	50CI414A-S		ICE/WATER MACHINE	1	EA	5,259.56	5,259.56

Subtotal:	5,259.56
Freight:	0.00
ORDER TOTAL:	\$5,259.56

Signature: _____

Date: _____



Quote

05/21/2025

To:
 Crawford County Memorial
 Hospital
 100 Medical Pkwy
 Denison, IA 51442
 Customer ID #012068

Project:
 Qoute #61712
 Chuck Tasler

From:
 Follett Products, LLC
 Larry Kirchhoff
 Medtek Resources, Inc.
 Saint Louis, MO 63122
 (314) 966-0221 (Primary)
 (610) 252-7301

Item	Qty	Description	Sell	Sell Total
1	1 ea	ICE & WATER DISPENSER Follett Products, LLC (Middleby) Model No. 50CI414A-S Symphony Plus™ ice and water dispenser, countertop with SensorSAFE™ dispense, removable air-cooled icemaker, up to 425 lb. production of Chewblet® nugget ice in 24 hours, 50 lb. storage capacity, Agion® silver-based antimicrobial protection, stainless steel cabinet with accent trim, 115v/60/1-ph	\$5,259.56	\$5,259.56
Total				\$5,259.56

Vizient Contract CE2851 pricing expires on 6/30/25.
 Non-contract pricing expires 60 days after the date of quotation.
 After that date, please contact your local sales representative.
 Specifications subject to change without notice.

This quote contains confidential pricing information intended only for the use of the individual or entity named above and may be legally privileged. If you are not an employee or agent of the intended recipient, you are hereby notified that any disclosure, copying, or distribution, in part or in whole, to any party not associated with the acceptance of this specific quote, or the taking of any action based on the contents of this quote, is strictly prohibited.

FREIGHT TERMS

Freight is an additional charge. Standard delivery rates include dock-to-dock services. Special services such as lift gate or inside delivery are not included. Please advise Follett Products, LLC at time of order if special services are needed.

All freight is to be inspected upon delivery. When shipped with Follett’s carrier, any freight received damaged must be refused or signed for as damaged. Follett Customer Service must be notified of any damage within 48 hours of delivery. If you choose to contract for the delivery of your equipment with your own third-party carrier, Follett is prohibited from submitting claims for freight damage on your behalf and cannot provide restitution for freight damage expenses. Should you experience freight damage with your own third-party carrier, Follett will help you document the event so that you can file the claim with your carrier.

RETURN POLICY

Follett equipment may be returned under the following conditions:

1. The equipment is new, unused, and not installed.
2. A return materials authorization (RMA) accompanies the returned equipment. Such RMA must be requested from Follett Customer Service within 45 days after shipment.
3. Equipment must be received at the Follett factory in Easton, PA within 30 days of the issuance of the

RMA by Follett.

4. There is a 20% re-stocking fee for all returns after equipment is inspected at Follett. If the cost to return the equipment to stock exceeds 20%, the actual cost will be deducted.

5. Return freight is the responsibility of the customer returning the equipment.

6. Units to be returned must be in brand new condition and in the original packaging. If you do not have the original packaging, please contact Follett Customer Service to order new packaging. If returned equipment is damaged because of improper packaging, Follett will not be held responsible.

Please Note: Special quote request (SQR) items are not returnable to Follett.

WARRANTY STATEMENT

Symphony Plus dispensers and Maestro Plus ice makers: 3 year parts and labor on entire machine, 5 year parts on compressor

Slope front bins: 3 year parts, 1 year labor

Medical-Grade Refrigerators and Freezers: 2 year parts and labor on entire machine, 5 year parts on compressor

Unless otherwise specified, all warranties cover repair or replacement of the product by an authorized service company. For full warranty terms, conditions, and exclusions please refer to the Warranty Statements available at <http://follettice.com/support/>.

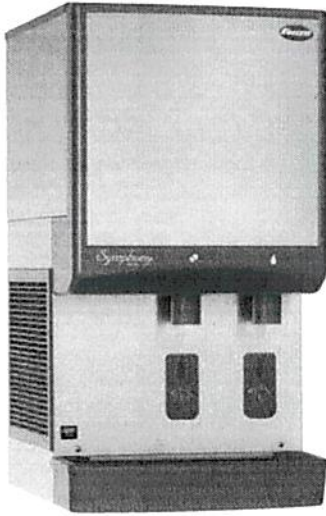

Shown with SensorSAFE™
SensorSAFE not recommended for use with clear containers or for applications in direct sunlight.



Symphony Plus™ ice and water dispenser

25 and 50 CI series countertop with Chewblet® ice machine

Features

- 25 or 50 lb (11.4 or 22.7 kg) ice storage capacity
- Counter-height removable air- or water-cooled ice machine with up to 425 lb (193.0 kg) daily production of Chewblet ice
 - modular ice machine slides out from behind lower front panel
 - soft, chewable, compressed nugget ice is ideal for patient care
 - Quiet Night™ sleep mode turns off ice machine when idle

Designed with sanitation in mind

- automatic self-flushing of ice machine removes impurities
- Agion® silver-based antimicrobial provides protection of key ice and water contact components¹
- one-hand lever or SensorSAFE infrared ice dispense

Dependable design, easy to service and clean

- cleaning and sanitizing of entire machine takes only 1 hour
- LED control board provides at-a-glance machine status
- panels are easily removed for accessibility to all components
- ice machine parts are common across all Symphony Plus dispensers
- stainless steel evaporator and auger deliver long life

Environmentally responsible

- R290 refrigerant has a low environmental impact and nominal global warming potential (GWP)
- continuous ice making process uses less electricity and water

Durable, attractive dispenser

- stainless steel cabinet with accent trim
- poly drain pan, grille and dispenser lid are corrosion-resistant
- secured top lid

Easy installation

- comes fully assembled and installs with three easy connections – electric, water and drain

Warranty

- 3 years parts and labor, 5 years compressor parts¹

Certifications (applied to all products unless otherwise noted)



Model configurations				
Ice storage capacity	Configuration	Dispense	Ice machine cooling	Item number
25 lb (11.4 kg)	ice and water	Lever	air	25CI414A-L
	ice-only	Lever	air	25CI414A-LI[†]
	ice and water	Lever	water	25CI414W-L
	ice-only	Lever	water	25CI414W-LI[†]
	ice and water	SensorSAFE	air	25CI414A-S
	ice-only	SensorSAFE	air	25CI414A-SI[†]
50 lb (22.7 kg)	ice and water	Lever	air	50CI414A-L
	ice-only	Lever	air	50CI414A-LI[†]
	ice and water	Lever	water	50CI414W-L
	ice-only	Lever	water	50CI414W-LI[†]
	ice and water	SensorSAFE	air	50CI414A-S
	ice-only	SensorSAFE	air	50CI414A-SI[†]
	ice and water	SensorSAFE	water	50CI414W-S
	ice-only	SensorSAFE	water	50CI414W-SI[†]

[†] ENERGY STAR® certified

Ice production		
Temperatures air/water	70/50 F (21/10 C)	90/70 F (32/21 C)
Air-cooled	425 lb (193.0 kg)	340 lb (154.4 kg)
Water-cooled	380 lb (172.5 kg)	330 lb (149.8 kg)
Energy consumption per 100 lb (45.4 kg) ice	N/A	6.0 kWh air-cooled 4.3 kWh water-cooled
Condenser water consumption	N/A	0.5 gpm (1.9 Lpm) at 70 F (21 C) water
Water consumption	12.0 gal (45.4 L) of potable water per 100 lb (45.4 kg) of ice	

Options and accessories²

- Base stand with or without factory installed water filter (refer to form# 7010)
- 4.00" (10.16 cm) leg kit (item# 00188417)
- Water filters (refer to form# 1058 and 8320)
- Pressurized water sanitizing kits (refer to form# 1068)
- SafeCLEAN Plus™ ice machine cleaner (refer to form# 8295)
- Nu-Calgon® IMS-III sanitizer (US only), 16 oz (0.5 L) bottle (item# 00979674)
- Additional Symphony Plus accessories (refer to form# 4025 or 2155)

¹ Refer to form# 4025 or 2155 for additional warranty information.

² Certifications do not apply to options and accessories.

Specification

Ice storage capacity	25 Series – 25 lb (11.4 kg) 50 Series – 50 lb (22.7 kg)
W1 Width, dispenser	21.00" (53.3 cm)
W2 Width, base stand accessory	22.75" (57.8 cm)
D1 Depth, entire dispenser	24.00" (61.0 cm)
D2 Depth, drain pan	7.00" (17.78 cm)
D3 Depth, base stand accessory	24.38" (61.9 cm)
H1 Height, dispenser	25 Series – 36.00" (91.4 cm) 50 Series – 40.00" (101.6 cm)
H2 Dispense height clearance	11.50" (29.2 cm)
H3 Height, base stand	33.00" (83.8 cm)
Ventilation clearance	air-cooled models only – 3.00" (7.62 cm) right, left and rear, 4.00" (10.16 cm) top
Service clearance	air-cooled models – 12.00" (30.5 cm) top, 6.00" (15.24 cm) left side water-cooled units – 12.00" (30.5 cm) top through back or bottom
Utility connection location	
C1 115 V/60/1 electrical	7.2 amps, .6.6' (2.0 m) cord with NEMA 5-15 90° hospital-grade plug
C2 Potable water inlet	3/8" FPT
C3 Drain	3/4" MPT
Refrigerant	air-cooled models – R290, 3.49 oz (99 g) water-cooled models – R290, 1.83 oz (52 g)
Water-cooled model connections	
C4 condenser inlet	3/8" FPT
C5 condenser drain	3/8" FPT
Heat rejection	air-cooled models – 5000 BTU/hr water-cooled models – 1400 BTU/hr to air, 3600 BTU/hr to water
Water flow requirement for water-cooled models	0.25 gpm (0.95 lpm) at 50 F (10 C) 0.5 gpm (1.90 lpm) at 70 F (21 C) 1.25 gpm (4.73 lpm) at 90 F (32 C)
Air temperature	50 - 100 F (10 - 38 C)
Water temperature	45 - 90 F (7 - 32 C)
Potable water pressure	10 - 70 psi (69 - 483 kpa)
Condenser water pressure	10 - 125 psi (69 - 861 kpa)
Approximate net weight	188 lb (85 kg)
Approximate ship weight	245 lb (111 kg)
Approximate ship weight, base stand accessory	95 lb (43 kg)
NOTE: For indoor use only	

SHORT FORM SPECIFICATION: (Choose one) ___ Ice and water or ___ ice-only dispenser to be Follett® automatic load in countertop configuration, with ___ 25 lb (11.4 kg) or ___ 50 lb (22.7 kg) of storage. Environmentally responsible R290 ice machine (choose one) ___ air- or ___ water-cooled and to be removable for cleaning and maintenance. Ice machine to produce approximately 425 lb (193.0 kg) of Chewblet compressed nugget ice at air temperature of 70 F (21 C), water temperature of 50 F (10 C). Ice machine equipped with automatic self-flushing and Quiet Night sleep mode. Dispenser to have automatic bin level control to start and stop ice machine. Storage area to be insulated with CARB compliant non-HFC foam. 6.6' (2.0 m) cord and NEMA 5-15 90° hospital-grade plug provided. NSF and UL listed.

Dimensional drawing

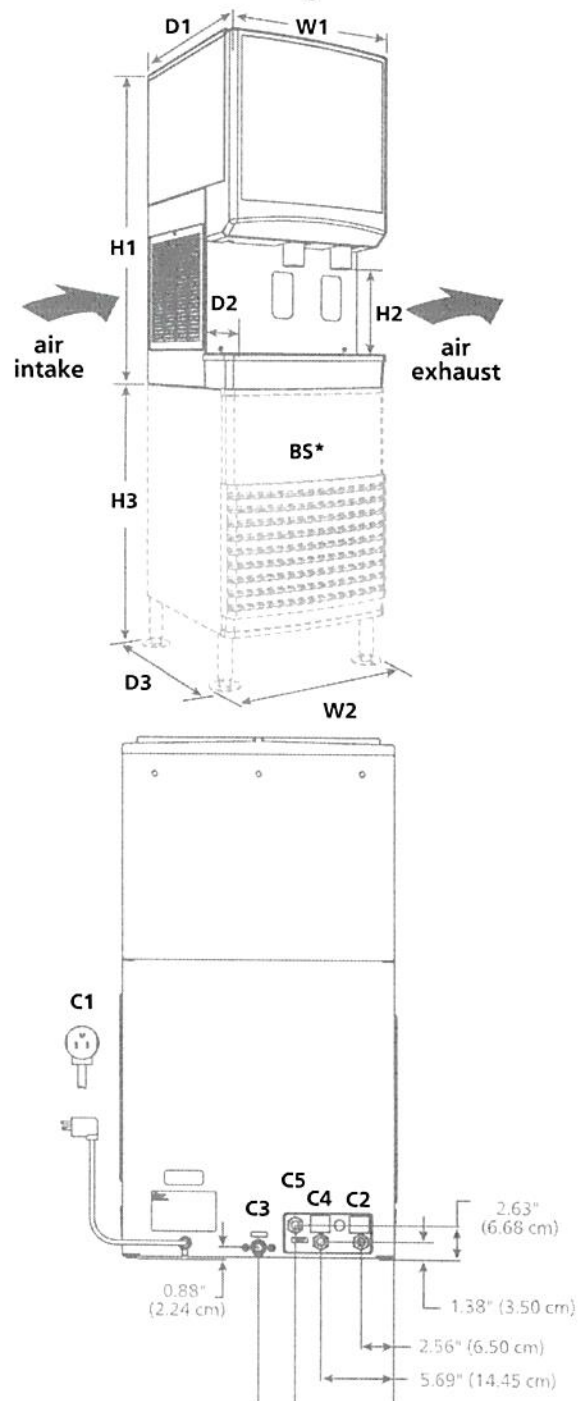

BS* – Base stand sold separately; measurements shown are with base stand legs at lowest position. See dispenser detail sheet, form# 6675, for counter cut outs.

¹ Disclaimer: Antimicrobial protection is limited to the treated components and does not treat water or ice.

ENERGY STAR and the ENERGY STAR mark are registered trademarks owned by the U.S. Environmental Protection Agency. Agion is a registered trademark of Sciessent LLC. SYMPHONY PLUS, SENSORSAFE, SAFECLEAN PLUS and QUIET NIGHT are trademarks of Follett Products, LLC. CHEWBLET and FOLLETT are registered trademarks of Follett Products, LLC, registered in the U.S. Follett reserves the right to change specifications at any time without obligation. Certifications may vary depending on country of origin.

25/50 CI series countertop

**Crawford County Memorial Hospital
PURCHASING DEPARTMENT REQUEST
Capital & Minor Equipment**

Date: 6/5/25

Department: ADMIN

Capital Equipment Item (>\$5,000): Yes Minor Equipment (\$1,000-\$5,000): Yes

In Current Fiscal Year Budget: Yes No

Is this a trial? Yes No If Yes, length of trial _____

If replacement, what item does it replace? _____

Item Requested: REMODEL OF SARA GAUL'S OFFICE FOR PATIENT EDUCATION

Quantity: 1

Description: DESK, TABLE, CHAIRS AND CABINET STORAGE

Justification of purchase: TO MEET PATIENTS IN HER OFFICE FOR EDUCATION

Pricing reviewed by MM: _____ ASCEND contract _____ MD Buyline checked _____

Reviewed by IT: _____ Reviewed by Plant Operations: _____

Reviewed by Bio-Med: _____ Service Manual Ordered: _____

In Buying Group?

Company #1: EAKES 9265.31 _____ Yes No

Company #2: _____ Yes No

Company #3: _____ Yes No

Recommendation: _____

Approved for purchase from _____ (Company)

Purchase Order #: _____ Date: _____

Signature: _____

Department Manager

Signature:  _____

CFO/CFO

CRAWFORD COUNTY MEMORIAL HOSPITAL
100 MEDICAL PARKWAY
DENISON, IA 51442

Phone: 712-265-2500

PURCHASE ORDER	
Purchase Order No.:	44079
Company No.:	CCMH
Vendor No.:	158175
Page No.:	1 of 1

Purchase Order Number above must appear on all correspondence.

VENDOR
EAKES INC. 617 WEST THIRD STREET P.O. BOX 2098 GRAND ISLAND, NE 68802-2098 PHONE: 402-412-2334 FAX: ACCT: 141374

INSTRUCTIONS
ADD ON CAPITAL 3rd Party Shipping - 354271435

SHIP TO
CRAWFORD COUNTY MEMORIAL HOSPITAL 100 MEDICAL PARKWAY DENISON, IA 51442

PAYMENT TERMS	FREIGHT TERMS	ORDER DATE
Due 30 Days		Jun 05, 2025

LINE	CATALOG	ITEM #	DESCRIPTION	QTY	UOM	PRICE	AMOUNT
1			REMODEL OF SARA GAUL'S OFFICE	1	EA	9,265.31	9,265.31

Subtotal:	9,265.31
Freight:	0.00
ORDER TOTAL:	\$9,265.31

Signature: _____

Rachel [Signature]

Date: _____

6/5/25

12 Locations Serving
the Midwest

www.eakes.com



510 W 13th Street
South Sioux City, NE 68776
(402) 412-2334

Quotation 67977

Quote Date 2025-06-04

Customer 141374

Terms 10th of every month

Account Representative Fred Sulzbach

Quote To

CRAWFORD MEMORIAL HOSPITAL
100 MEDICAL PARKWAY
Denison IA 51442

Ship To

CRAWFORD MEMORIAL HOSPITAL
100 MEDICAL PARKWAY
Denison IA 51442

Sales Location EAKES SIOUX CITY

Description	Quantity	Unit Price	Extended Price
Sara's Office			
1 HF27S - Satin Removable Lock Core Kit Select Key Number: .X126E: 126E HON Tag For Sara's Office	1	25.67	25.67
2 HLVMSC5630R - Mobile Stg Cab w/Bins 18"D x 30"W x 56"H Lock/Omt Opts: .L: Standard Random Key Lock Select Paint: \$(P1): P1 Paint Opts .LOFT: Loft HON Tag For Sara's Office 18x30	1	1,277.17	1,277.17
3 HIGS6DF - Ignition 2 Multi-purp Stack Chair, Four Leg,Dual Fab Select Arm Type: .F: Fixed Select Caster/Glide Option: .E: Nylon Glide Select Back: .U: Upholstered Select Back Upholstery: \$(7): Grade 7 Uph	3	361.20	1,083.60

12 Locations Serving
the Midwest

www.eakes.com



Eakes
office solutions

510 W 13th Street
South Sioux City, NE 68776
(402) 412-2334

Quotation 67977

Description	Quantity	Unit Price	Extended Price
3 .SCFSLVL: Level 2.0 52: Bavaria Select Seat Upholstery: \$(3): Grade 3 Uph .SX: Moxie 43: Concrete Select Frame Color: .PLAT: Textured Platinum Metallic HON Tag For Sara's Office HIGS6DF			
4 CC-P3636RT - Intermix 36x36x1 Round Top Top Finish, TFL Wood Grain: KD2: Kodiak (KD2) Edge Finish, PP: KD2: Kodiak (KD2) Power Cutout: QR: No Cutout (standard) OFS SALES Tag For Sara's Office CC-P3636RT	1	277.84	277.84
5 TSX32 - T 32" Static X Base for 36" Top Finish: H1FA: Warm Grey (with antimicrobial) Glide/Caster: A4F: Glides OFS SALES Tag For Sara's Office TSX32	1	373.98	373.98
6 LOCK-SET-4 - Set of 4 locks and keys. (pack of 4) Finish: NICKEL: Nickel ALIKE: Alike 345: 345 Standard # of Lock sets: 1: 1	1	0.00	0.00

12 Locations Serving
the Midwest

www.eakes.com



Eakes
office solutions

510 W 13th Street
South Sioux City, NE 68776
(402) 412-2334

Quotation 67977

Description	Quantity	Unit Price	Extended Price
6 OFS SALES Tag For Sara's Office LOCK-SET-4			
7 4-6043HD4-2 - Pulse 60x15X42.5 Highback Organizer-4 Doors Finish: ~ TFL-W: TFL Wood Grain KD2: Kodiak (KD2) Door: JB: TFL Panel LCK2: Requires 2 Lock Cores - Specific Key (Lock Sets Ordered Sepa Inside Back: W4: Tackboard/White Markerboard/Tackboard ~ MOM: Momentum ~ COVER CLOTH: Cover Cloth - Grade 5 3064752: Vesper OFS SALES Tag For Sara's Office 4-6043HD4-2	1	1,397.48	1,397.48
8 4-6630FLPD - Pulse 66x30 Left Full Pedestal Desk Finish: ~ TFL-W: TFL Wood Grain KD2: Kodiak (KD2) EY: Square Pull: Era: Era H1FA: Warm Grey with Antimicrobial Modesty Type: HLMD: Half Height Modesty Grommet: G5: Grommets Right and Left Lock: LCK1: Requires 1 Lock Core - Specific Key (Lock Sets Ordered Separ OFS SALES Tag For Sara's Office 4-6630FLPD	1	1,203.82	1,203.82

12 Locations Serving
the Midwest



www.eakes.com



Eakes
office solutions

510 W 13th Street
South Sioux City, NE 68776
(402) 412-2334

Quotation 67977

Description	Quantity	Unit Price	Extended Price
9 4-7236SCL - Pulse 36x72.5 Square-edge Storage Cabinet with Lateral File Finish: ~TFL-W: TFL Wood Grain KD2: Kodiak (KD2) Pull: Era: Era H1FA: Warm Grey with Antimicrobial Lock: LCK1: Requires 1 Lock Core - Specific Key (Lock Sets Ordered Separ OFS SALES Tag For Sara's Office 4-7236SCL	1	1,707.98	1,707.98
10 436AIR - Steelcase Series 2; Chair-Air back Air Back Finish: Plastic - PG1 6053 - SEAGULL Seat Finish: FOUNDATION 5880 - SEAL  Sewn Seat Upholstery: Sewn Color Scheme: Seagull Base Finish: Textured Paint 7243 - SEAGULL  Headrest Option: No Headrest Coat Hanger: No Coat Hanger Arm Type: Height,Width,Pivot,Depth Arm Cylinder Type: Standard Range Caster or Glide Type: Hard Casters Soil Retardant Option: No Soil Retardant Packaging: Not Applicable Steelcase Inc Tag For Sara's Office SERIES2	1	549.45	549.45
11 Steelcase Tariff Surcharge TARIFF SURCHARGE	1	18.32	18.32
Sub Total			7,915.31
SALES TAX NOT INCLUDED			0.00
Total			7,915.31
Deliver and Install			

12 Locations Serving
the Midwest

www.eakes.com



Eakes
office solutions

510 W 13th Street
South Sioux City, NE 68776
(402) 412-2334

Quotation 67977

Description	Quantity	Unit Price	Extended Price
12 Professionally receive, inspect, assemble, deliver and install product. LABORF	1	1,350.00	1,350.00
Sub Total			1,350.00
SALES TAX NOT INCLUDED			0.00
Total			1,350.00
Quotation Totals			
Sub Total			9,265.31
SALES TAX NOT INCLUDED			0.00
Grand Total			9,265.31

End of Quotation

12 Locations Serving
the Midwest

www.eakes.com



Eakes
office solutions

510 W 13th Street
South Sioux City, NE 68776
(402) 412-2334

Quotation 67977

Finish Summary

Product Line	Finish Group Description	Finish Description	Finish
	Select Key Number	.X126E - 126E	
	Lock/Omt Opts	.L - Standard Random Key Lock	
	Select Paint	.LOFT - Loft	
	Select Arm Type	.F - Fixed	
	Select Caster/Glide Option	.E - Nylon Glide	
	Select Back	.U - Upholstered	
	Select Back Upholstery	52 - Bavaria	
	Select Seat Upholstery	43 - Concrete	
	Select Frame Color	.PLAT - Textured Platinum Metallic	
	Top Finish, TFL Wood Grain	KD2 - Kodiak (KD2)	
	Edge Finish, PP	KD2 - Kodiak (KD2)	
	Power Cutout	QR - No Cutout (standard)	
	Finish	H1FA - Warm Grey (with antimicrobial)	
	Glide/Caster	A4F - Glides	
	Finish	345 - 345 Standard	
	# of Lock sets	1 - 1	
	Finish	KD2 - Kodiak (KD2)	
	Door	LCK2 - Requires 2 Lock Cores - Specific Key (Lock Sets Ordered Sepa	
	Inside Back	3064752 - Vesper	
	Finish	EY - Square	
	Pull	H1FA - Warm Grey with Antimicrobial	
	Modesty Type	HLMD - Half Height Modesty	
	Grommet	G5 - Grommets Right and Left	
	Lock	LCK1 - Requires 1 Lock Core - Specific Key (Lock Sets Ordered Separ	
Steelcase Series 2	Air Back Finish	6053 - SEAGULL	
Steelcase Series 2	Seat Finish	5880 - SEAL	
Steelcase Series 2	Base Finish	7243 - SEAGULL	



CRAWFORD COUNTY MEMORIAL HOSPITAL
Operating Budget for FY2026

	Actual FY2019	Actual FY2020	Actual FY2021	Actual FY2022	Actual FY2023	Actual FY2024	Annualized FY2025	Operating Budget FY2026
PATIENT REVENUE								
INPATIENT	7,770,329	8,121,239	8,341,407	7,061,018	6,043,008	4,622,084	6,889,323	7,570,440
OUTPATIENT	52,915,282	48,530,773	47,157,651	53,597,684	60,062,328	58,913,886	64,079,970	71,696,063
SWING BED	<u>468,636</u>	<u>397,651</u>	<u>337,945</u>	<u>265,843</u>	<u>353,103</u>	<u>652,261</u>	<u>1,346,096</u>	<u>1,633,070</u>
TOTAL PATIENT REVENUE	61,154,246	57,049,663	55,837,003	60,924,545	66,458,439	64,188,231	72,315,389	80,899,574
DEDUCTIONS FROM REVENUE								
MEDICARE ADJUSTMENTS	(12,462,979)	(10,360,416)	(11,062,352)	(11,217,473)	(13,824,270)	(14,406,955)	(15,682,710)	(17,934,941)
TITLE XIX ADJUSTMENTS	(3,827,337)	(3,990,189)	(2,036,848)	(3,600,870)	(4,053,460)	5,689,789	4,739,409	(728,621)
BLUE CROSS ADJUSTMENT	(7,873,343)	(8,175,809)	(7,314,267)	(7,580,515)	(6,433,458)	(6,421,392)	(7,491,128)	(8,206,072)
OTHER ADJUSTMENTS	(1,917,327)	(2,092,107)	(1,531,521)	(2,355,353)	(3,904,240)	(3,638,521)	(4,227,749)	(4,216,729)
PROVISION FOR UNCOLLECT	(1,787,318)	(1,635,981)	(1,481,937)	(1,347,565)	(1,620,726)	(1,796,839)	(1,884,199)	(2,015,000)
CHARITY CARE	<u>(220,518)</u>	<u>(244,536)</u>	<u>(165,035)</u>	<u>(239,181)</u>	<u>(250,514)</u>	<u>(225,454)</u>	<u>(175,066)</u>	<u>(205,000)</u>
REDUCTION OF EARNINGS	(28,088,821)	(26,499,039)	(23,591,961)	(26,340,956)	(30,086,667)	(20,799,372)	(24,721,445)	(33,306,364)
NET PATIENT REVENUE	33,065,425	30,550,624	32,245,043	34,583,589	36,371,771	43,388,859	47,593,945	47,593,210
% OF Gross Revenue	-45.93%	-46.45%	-42.25%	-43.24%	-45.27%	-32.40%	-34.19%	-41.17%
OTHER REVENUE								
DIETARY/MEALS INCOME	91,344	93,575	75,238	78,834	78,099	74,444	80,343	84,500
OTHER INCOME	<u>2,072,230</u>	<u>2,177,650</u>	<u>1,905,259</u>	<u>1,638,345</u>	<u>2,733,941</u>	<u>1,576,315</u>	<u>1,765,679</u>	<u>1,322,400</u>
OTHER OPERATING REVENUE	2,163,575	2,271,225	1,980,497	1,717,179	2,812,041	1,650,759	1,846,022	1,406,900
TOTAL OP REVENUE	35,229,000	32,821,850	34,225,540	36,300,768	39,183,812	45,039,617	49,439,967	49,000,110
OPERATING EXPENSES								
SALARIES	18,222,957	18,572,820	17,215,770	18,404,711	19,838,245	19,763,927	20,260,713	24,573,603
BENEFITS	5,594,978	6,723,340	6,181,322	3,221,561	4,248,612	5,070,826	5,144,304	8,063,131
PROFESSIONAL FEES	2,486,838	1,587,777	1,551,220	2,497,098	2,834,341	3,277,083	3,758,703	3,188,219
SUPPLIES & EXPENSES	6,755,950	6,191,209	6,722,244	6,412,172	7,411,690	7,994,494	8,902,640	9,046,447
LEGAL & ACCOUNTING	119,577	88,839	133,011	117,957	173,182	175,752	166,719	180,000
MARKETING & ADVERTISING	196,510	161,751	117,618	143,437	158,006	169,001	170,680	190,560
MINOR EQUIPMENT	194,112	158,464	210,993	159,573	177,213	226,277	185,252	245,500
OCCUPANCY	1,160,400	1,336,049	1,216,563	1,411,214	1,583,302	1,564,340	1,804,440	1,863,240
DEPRECIATION	<u>2,693,456</u>	<u>2,593,785</u>	<u>2,620,442</u>	<u>2,642,304</u>	<u>2,684,463</u>	<u>2,012,330</u>	<u>2,325,500</u>	<u>2,685,000</u>
TOTAL EXPENSE	37,424,777	37,414,033	35,969,184	35,010,026	39,109,054	40,254,030	42,718,952	50,035,700
OPERATING INCOME (LOSS)	(2,195,777)	(4,592,183)	(1,743,644)	1,290,742	74,758	4,785,588	6,721,015	(1,035,590)
NONOPERATING GAINS								
INTEREST INCOME	151,404	179,084	60,697	9,387	203,513	599,884	1,263,191	1,400,000
INTEREST EXPENSE	(1,040,166)	(1,028,781)	(1,102,795)	(783,571)	(690,239)	(656,835)	(1,699,295)	(1,976,000)
DEBT ISSUANCE EXPENSE	-	-	-	-	-	-	-	-
CONTRIBUTION TO WELLNESS CENTER	-	-	-	-	-	(500,000)	-	-
GENERAL CONTRIBUTIONS	3,413	690	1,058	78,631	2,666	17,990	20,633	12,000
COVID/PRF/FEMA FUNDING	-	4,683,348	258,592	1,216,711	192,799	1,180,110	-	-
PPP LOAN FORGIVENESS	-	-	3,095,100	-	-	-	-	-
TAX INCOME	<u>1,721,378</u>	<u>1,713,314</u>	<u>2,040,318</u>	<u>2,019,962</u>	<u>2,013,634</u>	<u>2,076,233</u>	<u>2,180,908</u>	<u>1,990,757</u>
TOTAL NONOP GAINS	836,029	5,547,656	4,352,970	2,541,121	1,722,374	2,717,382	1,765,437	1,426,757
NET REVENUE (LOSS)	(1,359,749)	955,473	2,609,326	3,831,862	1,797,132	7,502,970	8,486,453	391,167
Net margin	-3.86%	2.91%	7.62%	10.56%	4.59%	16.66%	17.17%	0.80%

CRAWFORD COUNTY MEMORIAL HOSPITAL						
	2026 Capital Budget	Requested FY2026	Deferred FY2027	Contingent FY2026	Recommended Foundation	Approved 2026 Budget
Administration						
	Crisis Auscultation Manikin	\$15,000			\$15,000	\$15,000
	Simulaids ALS Full Body Manikin	\$6,000				\$6,000
Ambulance						
	Ford F-450 Superline Ambulance - ordered	\$113,930				\$113,930
Dietary						
	Bench Mixer	\$15,000		\$15,000		
ER						
	Wall Coverings/Drywall repair	\$25,000				\$25,000
IT						
	Update SQL Server	\$6,000				\$6,000
	Conversion of O365 Cloud Services (email)	\$60,000				\$60,000
	Building Remodel Devices	\$575,000	\$90,000			\$485,000
	Patient Intake Software - automatic check-in/appt reminders	\$50,000				\$50,000
	Rehab Services Software Interface	\$20,000				\$20,000
	Update VMWare Environment	\$15,000				\$15,000
	Update ISE/Reconfigure Wireless SSIDs	\$20,000				\$20,000
	Server Room - Cooling/Rack PDUs/UPS	\$300,000	\$300,000			
	Vocera	\$35,000		\$35,000		
Lab						
	Refrigerator/Freezer replacements	\$46,000				\$46,000
	Hematology Analyzer	\$60,000	\$60,000			
	Coagulation Analyzer	\$35,000				\$35,000
Medical Clinic						
	EKG (GE)	\$22,000		\$22,000		
Medical Unit						
	Maxi Move w/scale	\$15,000				\$15,000
	Sara Flex w/scale	\$8,000				\$8,000
	Bariatric Bed	\$55,000				\$55,000
	Bladder Scanner (additional)	\$15,000	\$15,000			
	Nurse Call System	\$541,222				\$541,222
MRI						
	MRI (including construction)	\$2,375,000				\$2,375,000
Pharmacy						
	Omnicell Cabinet upgrades	\$46,000				\$46,000
Physical Therapy						
Plant Operations						
	Door Replacement	\$110,000				\$110,000
	New V-plow for Pick-up	\$12,500				\$12,500
	Side by Side for construction, groundskeeping, snow removal	\$35,500	\$35,500			
	Concrete Parking Lot Replacement	\$140,000		\$140,000		
	Skid Loader Replacement	\$42,000				\$42,000
	Storm Drain replacements - 2	\$30,000				\$30,000
	Windows on Med Unit - 5	\$15,000				\$15,000
Purchasing						

